

Technical Specification

Type: Vacuum Tumbler

FPE's new VT Series of Vacuum Tumblers have been designed and built to exacting specifications, incorporating many years experience in the food industry.

We have built this range of machines to be robust enough to handle the toughest of applications, uncompromising in quality yet keeping the machines simple, easy to maintain and cost effective. Utilising the best available manufacturing techniques has enabled us to offer high quality machinery with real **value-for-money** prices in today's market.

SERIES	VT Vacuum Tumbler
MODEL	VT-1200/1500/2500
DESCRIPTION	Massaging and Marinating

The VT-1200, VT-1500 and VT-2500 Vacuum Tumblers have a 1200 litre, 1500 litre and 2500 litre volume body respectively. The VT-1200/1500/2500 machines have a two speed drum and interval vacuumisation. The machines also come with simple to use electromechanical controls.

The VT Series of Vacuum Tumblers have been designed with simplicity in mind and as such are less sophisticated than the FVT series of Vacuum Tumblers, ensuring this simple range of machines are real value for money.

The machines are suitable for a wide range of tumbling, massaging and marinating operations.

The VT Series can be tailored to customer's specific requirements, including electrical components and software integration.



MODEL	VT-1200	VT-1500	VT-2500
CAPACITY	Up to 500 kg	Up to 700 kg	Up to 1000 kg
VOLUME	1200 litre	1500 litre	2500 litre
POWER	6.6 kW	6.6 kW	9.5 kW
DRUM SPEED	7/11 rpm	7/11 rpm	7/11 rpm
VACUUM	-80 kPa	-80 kPa	-80 kPa
EXTERNAL DIMENSIONS	1.9 x 1.3 x 1.9 m	2.1 x 1.3 x 1.9 m	2.6 x 1.4 x 2.0 m
WEIGHT	800 kg	1000 kg	1200 kg

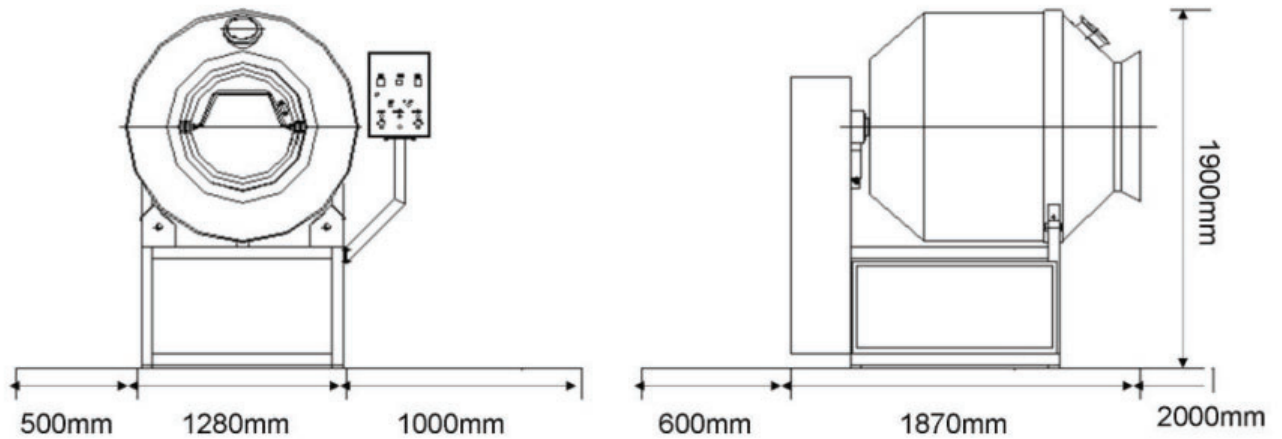

VT-1200 external dims. and clear working space required

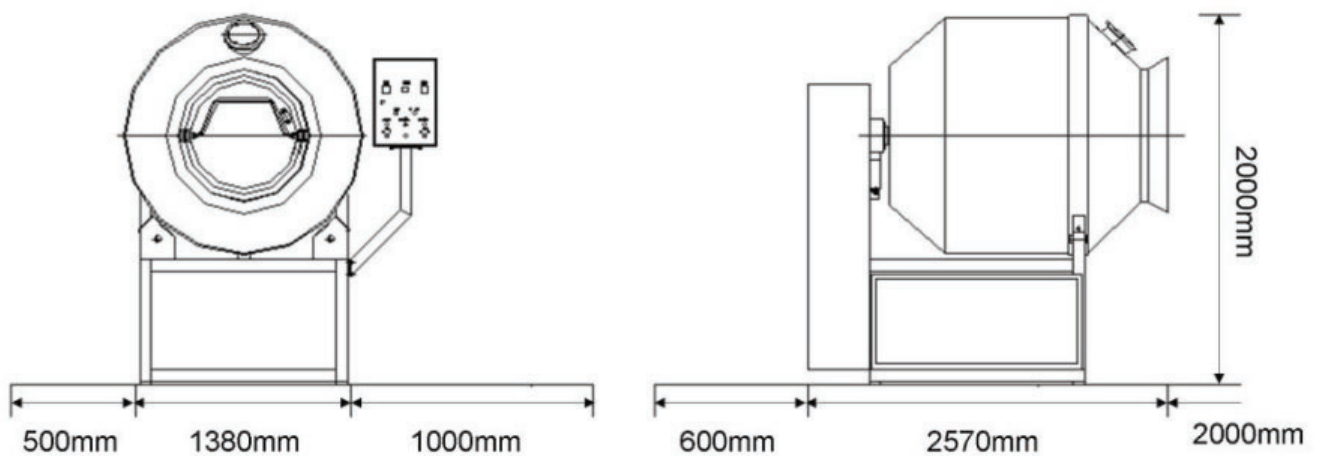

VT-2500 external dims. and clear working space required