

Technical Specification

Type: Inclined Vacuum Tumbler

FPE's new IVT Series of Vacuum Tumblers have been designed and built to exacting specifications, incorporating many years experience in the food industry.

We have built this range of machines to be robust enough to handle the toughest of applications, uncompromising in quality yet keeping the machines simple, easy to maintain and cost effective. Utilising the best available manufacturing techniques has enabled us to offer high quality machinery with real **value-for-money** prices in today's market.

SERIES	IVT Vacuum Tumbler
MODEL	IVT-1700/2500
DESCRIPTION	Massaging and Marinating

The IVT-1700 and IVT-2500 Inclined Vacuum Tumblers have a 1700 litre and 2500 litre volume body respectively. The drum speed is inverter controlled and the machines come with Touch Screen PLC controls as standard.

The IVT Series of Vacuum Tumblers have 10 modes of tumbling pre-stored and up to 100 formulas can be programmed. The forward, reverse, intervals and conditioning cycles can all be adjusted for ultimate versatility.

The machines are supplied with automatic loading and discharge systems.

The IVT Series can be tailored to customer's specific requirements, including electrical components and software integration.



MODEL	IVT-1700	IVT-2500
CAPACITY	Up to 1000 kg	Up to 1500 kg
VOLUME	1700 litre	2500 litre
POWER	7.5 kW	9.5 kW
DRUM SPEED	4 ~ 11 rpm	4 ~ 11 rpm
VACUUM	-85 kPa	-85 kPa
EXTERNAL DIMENSIONS	3.0 x 1.8 x 2.1 m	3.5 x 2.0 x 2.4 m
WEIGHT	1600 kg	1800 kg

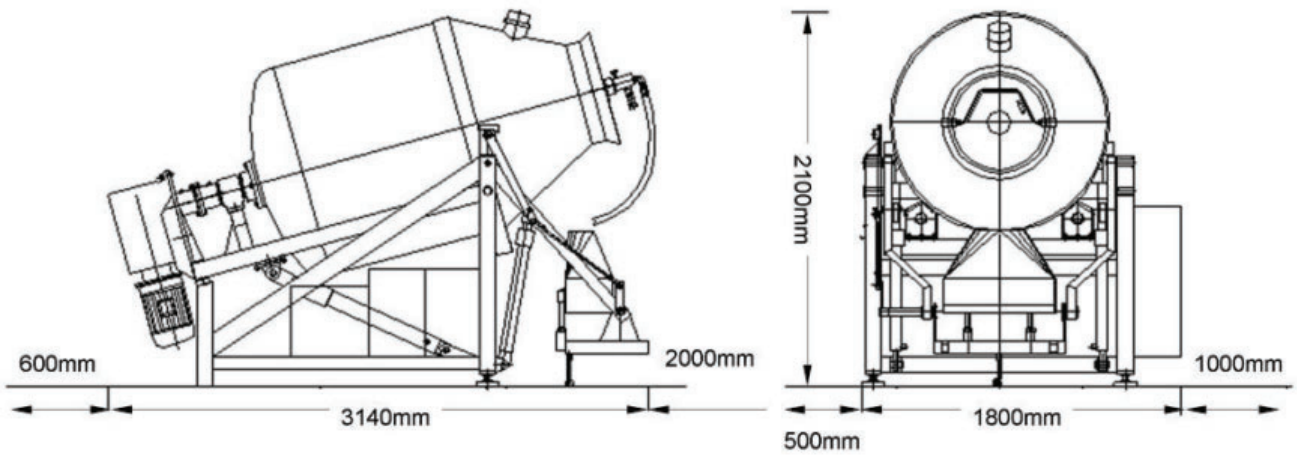

IVT-1700 external dims. and clear working space required



IVT-1700 shown with loading device