



Technical Specification

Type: Mixer

FPE's new FM Series of Food Mixers have been designed and built to exacting specifications, incorporating many years experience in the food industry.

We have built this range of machines to be robust enough to handle the toughest of applications, uncompromising in quality yet keeping the machines simple, easy to maintain and cost effective. Utilising the best available manufacturing techniques has enabled us to offer high quality machinery with real **value-for-money** prices in today's market.

SERIES	FM Mixer
MODEL	FM-230
DESCRIPTION	Mixing and Blending

The FM-230 mixer has a 230 litre volume hopper and incorporates a twin-shaft paddle design. The FM-230 comes with simple to use push button controls and has a manual hand wheel for regulated discharge control.

The FM-230 is ideal for small butchers and caterers who require efficient mixing and blending of batches up to 150kg.

The FM series of mixers are designed to be suitable for a large range of applications within the food manufacturing industry and can be tailored to suit individual customers specific requirements.





MODEL	FM-230
CAPACITY	150 kg
POWER	4 kW
VOLUME	230 litre
SHAFT SPEED	73 rpm
VACUUM	N/A
EXTERNAL DIMENSIONS	1.25 x 0.7 x 1.2 m
WEIGHT	300 kg

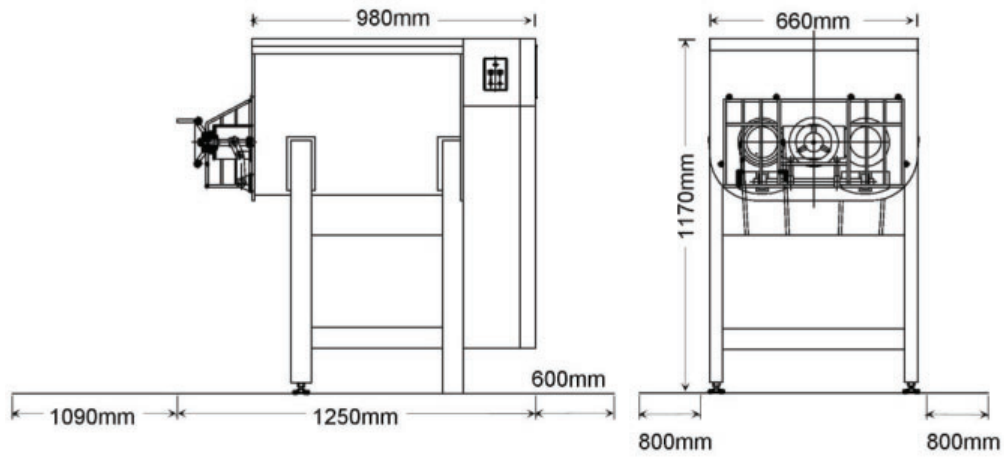

FM-230 external dims. and clear working space required



Mixing paddles on the FM-230