

Technical Specification

Type: Bowl Chopper

FPE's new FBC and FVB Series of Bowl Choppers have been designed and built to exacting specifications, incorporating many years experience in the food industry.

We have built this range of machines to be robust enough to handle the toughest of applications, uncompromising in quality yet keeping the machines simple, easy to maintain and cost effective. Utilising the best available manufacturing techniques has enabled us to offer high quality machinery with real **value-for-money** prices in today's market.

SERIES	FBC & FVB Bowl Chopper
MODEL	FBC/FVB-330
DESCRIPTION	Fine Cutting & Emulsions

The FBC-330 bowl chopper has a 330 litre bowl, inverter controlled cutting and bowl speed, a six bladed cutting set and is fitted with automatic loading and discharge mechanisms.

The FVB-330 has the same features as above but also incorporates vacuum bowl chopping with CO2 or N2 addition and Touch Screen PLC controls.

The FBC Series of bowl choppers are suitable for a variety of applications including; all types of sausage mix/emulsion, ground beef and pork, hamburgers, pate, salami and hot dog emulsions.

The FBC/FVB-330 can be tailored to customer's specific requirements, including electrical components and software integration.

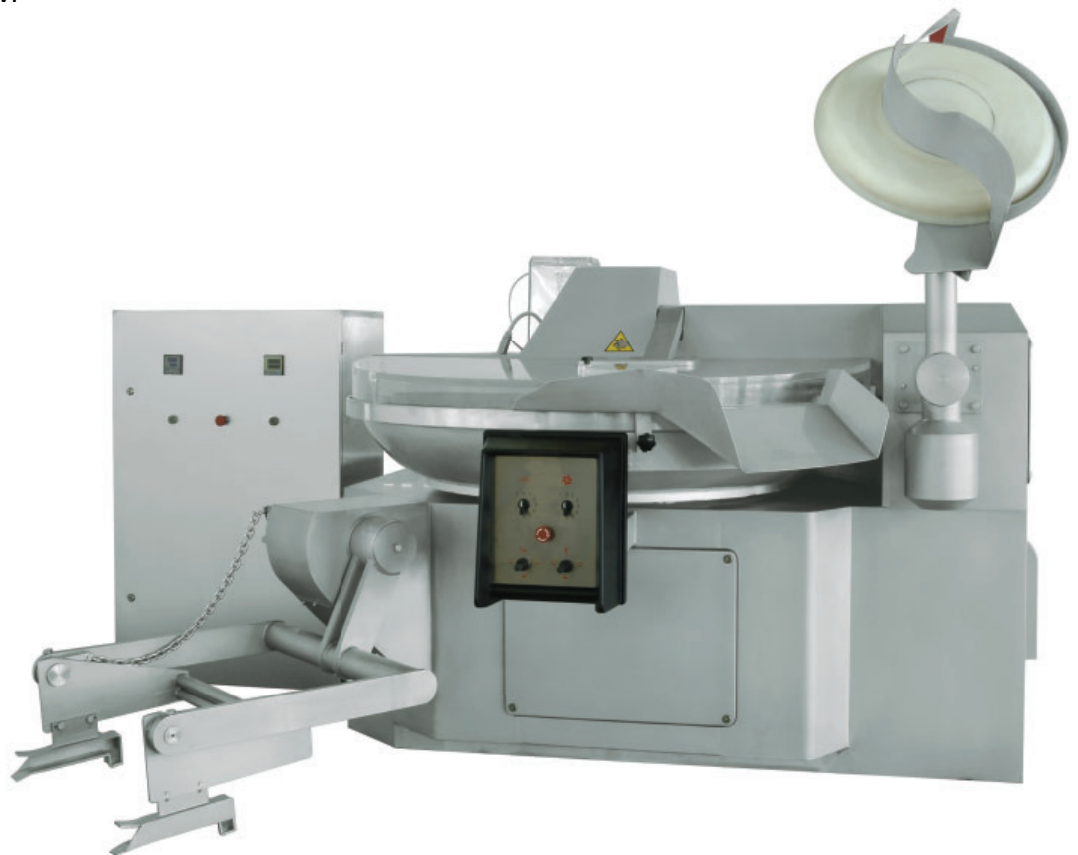



MODEL	FBC-330	FVB-330
CAPACITY	Up to 260 kg	Up to 260 kg
VOLUME	330 litre	330 litre
POWER	90 kW	118 kW
SHAFT SPEED	300 ~ 3600 rpm	300 ~ 3800
BOWL SPEED	8 ~ 12 rpm	8 ~ 12 rpm
DISC SPEED	Inverter controlled	Inverter controlled
KNIVES	6	6
EXTERNAL DIMENSIONS	2.5 x 2.2 x 1.9 m	2.5 x 2.2 x 2.1 m
WEIGHT	4500 kg	5800 kg

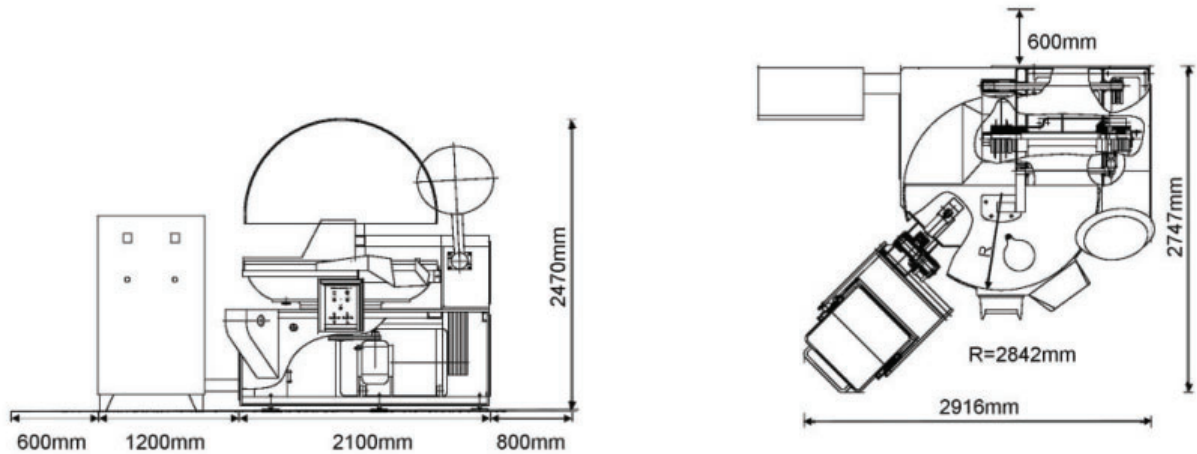

FBC-330 external dims. and clear working space required



Cutting set on the FBC Series