



Technical Specification

Type: Bowl Chopper

FPE's new FBC Series of Bowl Choppers have been designed and built to exacting specifications, incorporating many years experience in the food industry.

We have built this range of machines to be robust enough to handle the toughest of applications, uncompromising in quality yet keeping the machines simple, easy to maintain and cost effective. Utilising the best available manufacturing techniques has enabled us to offer high quality machinery with real **value-for-money** prices in today's market.

SERIES	FBC Bowl Chopper
MODEL	FBC-80
DESCRIPTION	Fine Cutting & Emulsions

The FBC-80 bowl chopper has a 80 litre bowl, three settings for cutting speed, two settings for the bowl speed, a six bladed cutting set and unloading disk as standard.

The FBC-80 is ideal for smaller butchers and caterers who want to produce emulsions of up to 40 kg batches.

The FBC Series of bowl choppers are suitable for a variety of applications including; all types of sausage mix/emulsion, ground beef and pork, hamburgers, pate, salami and hot dog emulsions.

The FBC-80 can be tailored to customer's specific requirements, including electrical components and software integration.





MODEL	FBC-80
CAPACITY	Up to 40 kg
VOLUME	80 litre
POWER	15 kW
SHAFT SPEED	200/1500/3000 rpm
BOWL SPEED	11/17 rpm
DISC SPEED	83 rpm
KNIVES	6
EXTERNAL DIMENSIONS	1.9 x 1.2 x 1.3 m
WEIGHT	1200 kg

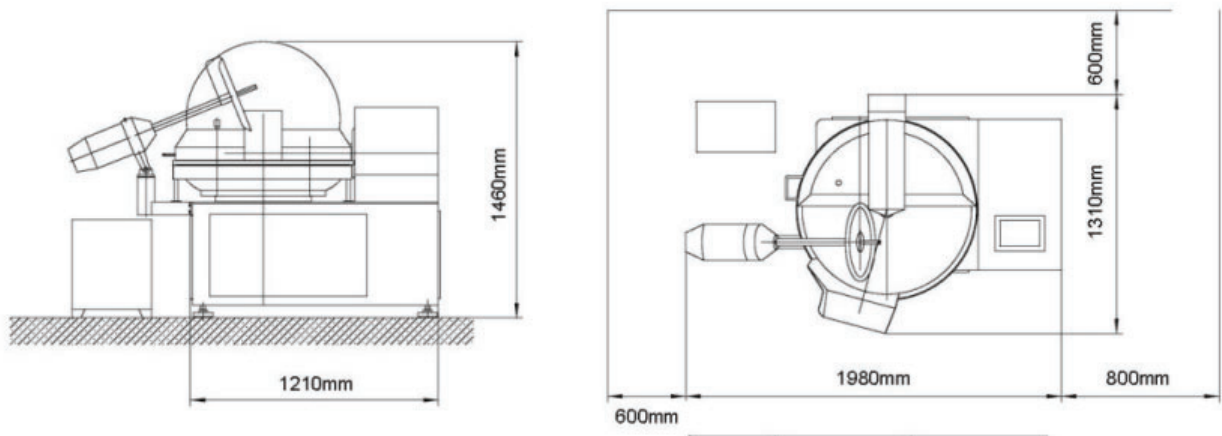

FBC-80 external dims. and clear working space required



Cutting set on the FBC Series