

Technical Specification

Type: Bowl Chopper

FPE's new FBC Series of Bowl Choppers have been designed and built to exacting specifications, incorporating many years experience in the food industry.

We have built this range of machines to be robust enough to handle the toughest of applications, uncompromising in quality yet keeping the machines simple, easy to maintain and cost effective. Utilising the best available manufacturing techniques has enabled us to offer high quality machinery with real **value-for-money** prices in today's market.

<b>SERIES</b>	FBC Bowl Chopper
<b>MODEL</b>	FBC-125
<b>DESCRIPTION</b>	Fine Cutting & Emulsions

The FBC-125 bowl chopper has a 125 litre bowl, three settings for the cutting speed, two settings for the bowl speed, a six bladed cutting set and unloading disk as standard. It can also be supplied with a larger motor and inverter controlled cutting speed.

The FBC-125 is ideal for medium sized butchers and caterers who want to produce emulsions of up to 70 kg batches.

The FBC Series of bowl choppers are suitable for a variety of applications including; all types of sausage mix/emulsion, ground beef and pork, hamburgers, pate, salami and hot dog emulsions.

The FBC-125 can be tailored to customer's specific requirements, including electrical components and software integration.





MODEL	FBC-125	FBC-125 II
CAPACITY	Up to 70 kg	Up to 70 kg
VOLUME	125 litre	125 litre
POWER	40 kW	47 kW
SHAFT SPEED	200/1650/3300 rpm	300 ~ 4500
BOWL SPEED	11/17 rpm	11/17
DISC SPEED	83 rpm	83 rpm
KNIVES	6	6
EXTERNAL DIMENSIONS	1.9 x 1.4 x 1.3 m	2.2 x 1.4 x 1.35 m
WEIGHT	1800 kg	2000 kg

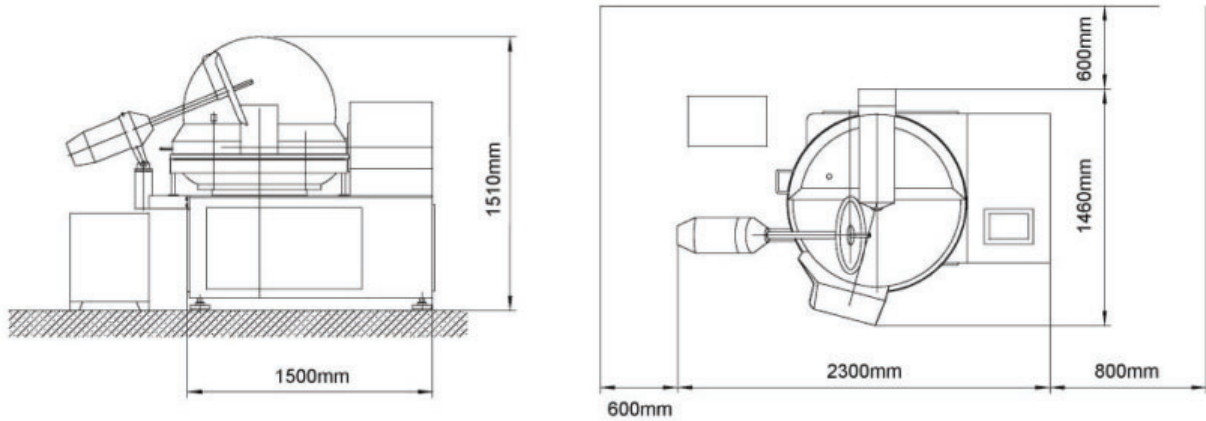

*FBC-125 external dims. and clear working space required*



*Cutting set on the FBC Series*